



TECHNISCHE DATEN

Power connection	No power connection
Compressed air connection	nein
PC connection	No PC connection
Width / Diameter	60 cm
Depth	50 cm
Height	45 cm
Weight (net)	45 kg

NORMEN

ISO 7263
PAPTAC D29
SCAN P27
TAPPI T809

Ingenieurbüro Walter

all4test

Tel.: +49 (0)9842 - 9 36 96 30 · Fax: +49 (0)9842 - 9 36 96 33 · info@all4test.de
[ib-walther](http://ib-walther.com) · Willy-Brand-Straße 4 · D-97215 Uffenheim · www.all4test.de



MANUAL PUNCH & DIE PRESSES Paper & Cardboards

- > Modelo MP-10 (12,7x152,4 mm)
- > Modelo MP-15 (15x300 mm)
- > Modelo MP-25 (25x300 mm)
- > Modelo MP-100 (100 cm²)

Precision punch & die presses to cut rectangular or circular precision samples with high accuracy, +/- 0.1 mm in order to evaluate Tensile, Basis Weight, SCT, CMT, RCT, CCT, CLT... for Paper (Liner / Medium)



MANUAL PUNCH & DIE PRESSES “MP” series

APPLICABLE STANDARDS

ISO 3035 - ISO 7263 - ISO 3037 - ISO 536 - ISO 1924-2 - TAPPI T822 - TAPPI T809 - TAPPI T494...

GENERAL INFORMATION

The MP series manual cutting presses have been designed to quickly obtain, in a single operation, samples of paper, compact board, cardboard, tissue paper, aluminum foil ... of a certain size depending on the model.

It consists of a fixed counter blade (female) and a movable blade (male) made of ground steel.

The Presses have a mobile platform system with a self-adjusting spring to press and hold the samples in place, this causes blocking and adjustment of the samples and also prevents the formation of wrinkles in the samples during cutting (important in samples of soft materials such as tissue paper or light weight paper), which guarantees a high-precision cut.



- Easy to use
- Safety of use
- Robust design
- Cutting precision

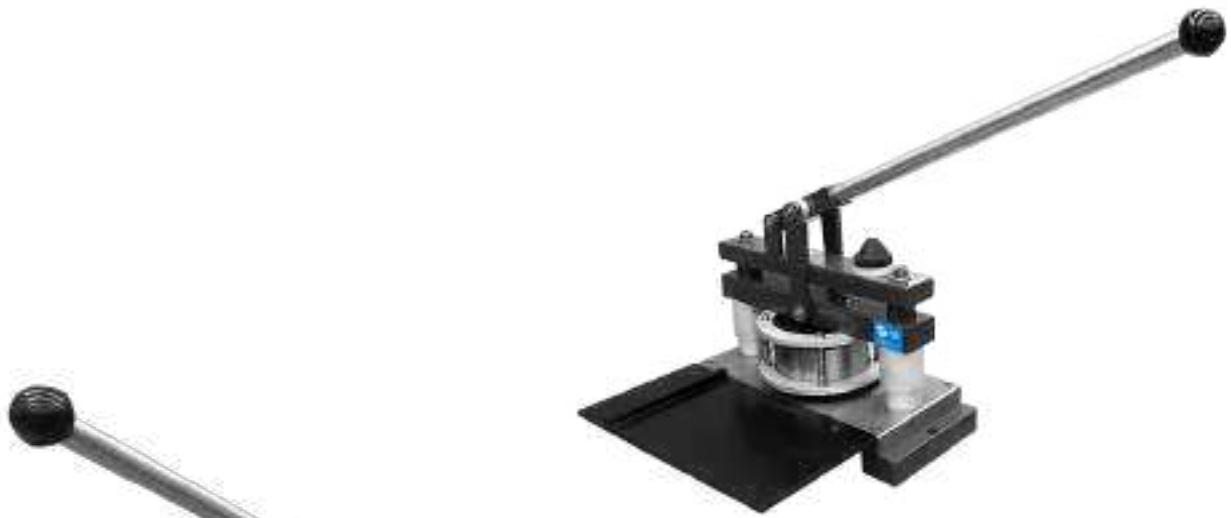

MP-100 (100 Cm²)



MP-10 (12,7x152,4 mm)

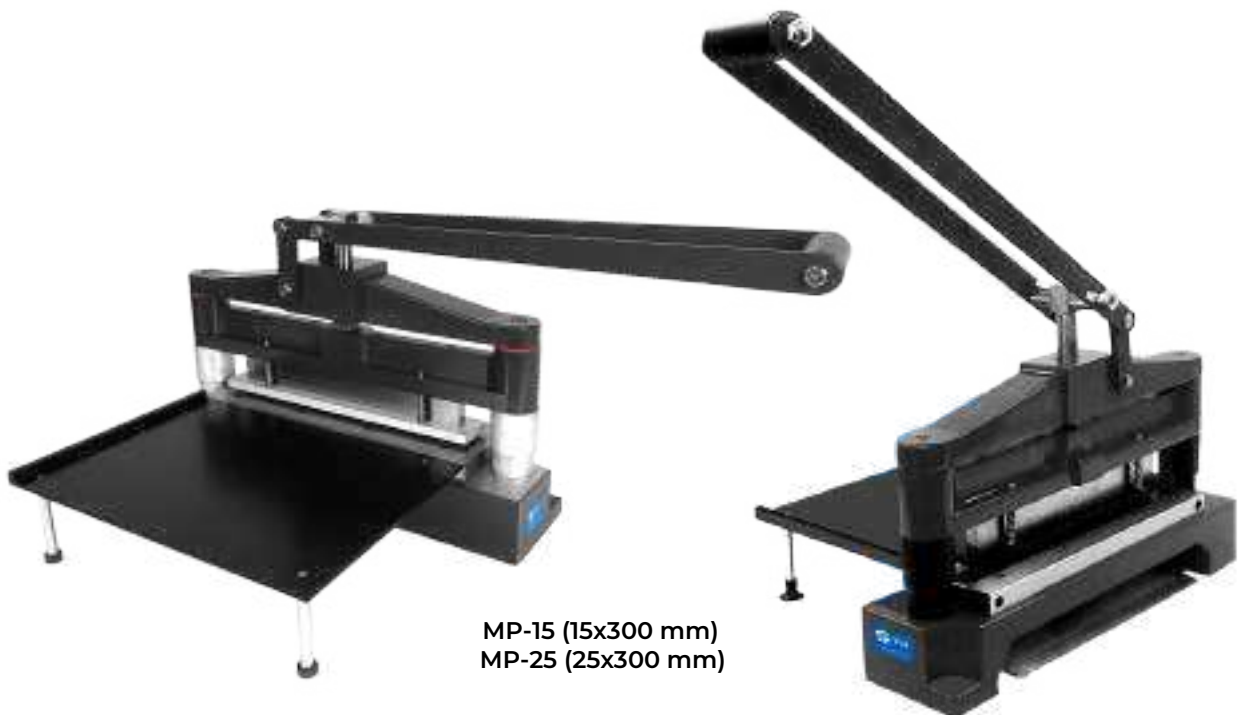

MP-15 (15x300 mm)
MP-25 (25x300 mm)



Model MP-10, MP-15 and MP-25 presses are equipped with an inclined platform underneath the blades so that the already cut samples can slide and in this way they can be easily extracted.

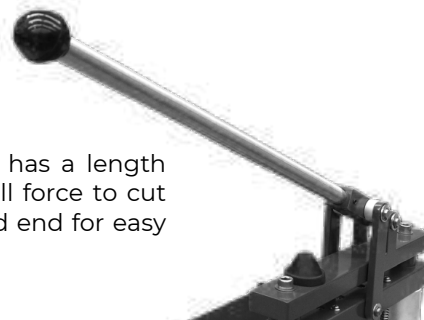

The lever is easy to operate, it has a length and a push system with a small force to cut quickly. They have the threaded end for easy disassembly when necessary.



The Model MP-15 and MP-25 presses, due to their long cutting length of 300 mm, use a special double lever system, requiring very little effort to cut the samples.

The MP series presses are equipped with a platform located on the left side, which allows cutting samples by sliding them in the same cutting plane, which facilitates cutting with greater precision.



MANUAL SAMPLE CUTTING PRESSES MP series

Model	Cutting size mm/ cm ²	Precision Cut mm	Cutting size Inches	Dimensions Press mounted W x D x H /mm	Net Weight Kg	Packaging Dimensions W x D x H /mm	Gross Weight kg
MP-10	12,7x152,4 mm	±0,1 mm	1/2 x 6 in.	330x360x400	20	650x450x480	37
MP-15	15x300 mm	±0,1 mm	0,59x11,81 in.	380x500x650	27	730x380x550	48
MP-25	25x300 mm	±0,1 mm	0,98/1x11,81 in.	380x500x650	27	730x480x550	50
MP-100	100 cm ²	±0,1 mm	15,50 inch ²	300x360x400	24	570x370x340	40

STANDARD SUPPLY CONTENT:

* MP series manual cutting press, the requested model